

FOR OFF ROAD/RACE USE ONLY!



Driven ZX 636 Fender Eliminator

Part # DKZ-050/051

Installation Instructions

Removal

1. Remove rear passenger seat
2. Remove mounting bolts for rear license plate assembly. see Fig.1

Tools Required

- 8mm Open End Wrench
- 5mm Hex Key
- 6mm Hex Key
- 8mm Hex Key
- Needle Nose Pliers
- Screw Driver
- Blue Loctite
- Impact Gun

Remove Fig. 1

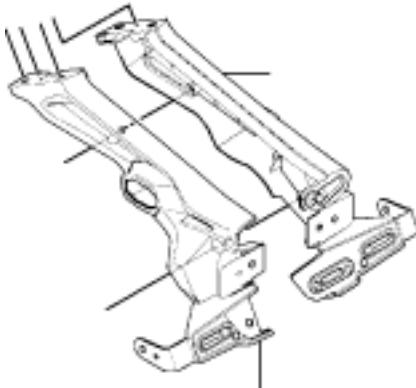

THE USE OF BLUE LOCTITE IS REQUIRED ON ALL MOUNTING HARDWARE!

Installation

1. Install fender eliminator main plate using supplied M6 bolts and nuts (use blue Loctite)
2. Adjust angle of plate holder to desired position
3. Turn signals and or license plate light are sold separately

TORQUE VALUES

- M5 = 6FT/LBS
- M6 = 10FT/LBS
- M8 = 25FT/LBS
- M10 = 45FT/LBS

Note. Inspect brake light turn signals and license plate light for proper operation prior to riding.

Note. Make sure to tighten all bolts and nuts to proper spec and use Loctite on all fasteners

THIS PRODUCT IS INTENDED TO BE INSTALLED BY A CERTIFIED TECHNICIAN*

FOR OFF ROAD/RACE USE ONLY!



DRIVEN PERFORMANCE PRODUCTS

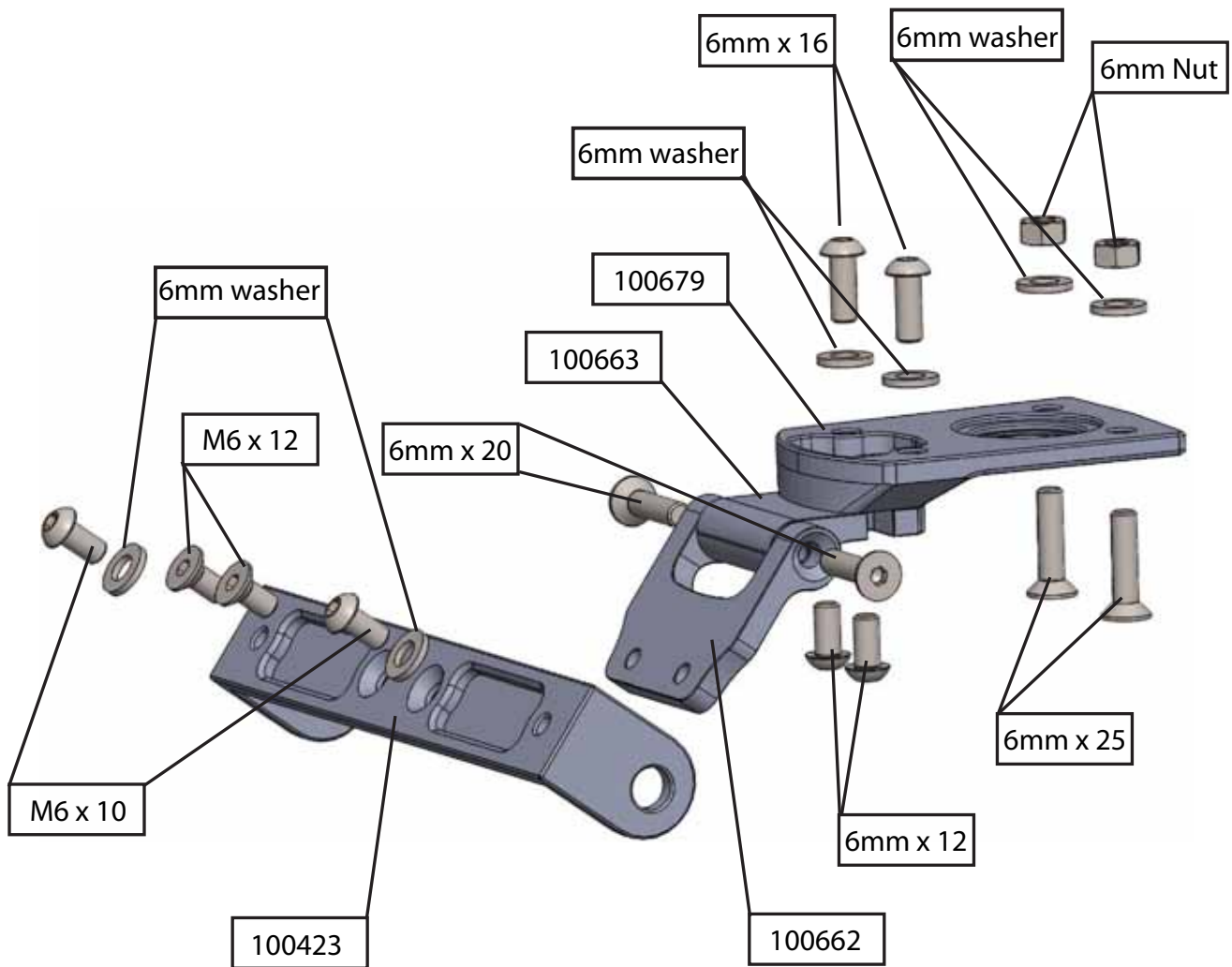

THIS PRODUCT IS INTENDED TO BE INSTALLED BY A CERTIFIED TECHNICIAN*